



More Precision

wireSENSOR // Draw-wire displacement sensors





- Use almost any encoder
- Robust aluminium profile housing
- High quality sensor components

Rugged draw-wire mechanics for encoder mounting

The wireSENSOR mechanics of the Z60, P96, P115 and P200 series are designed for easy mounting of an incremental or absolute encoder. The selection of the interface, resolution and type of connection can therefore be individually configured. Optimum matching to the signal conditioning system is ensured. High precision components and a rugged housing offer high operational reliability and a long life time even under harsh industrial conditions.

A complete measurement unit always consists of the basic draw-wire mechanism and the adapter for the customer-specific encoder. The adapter contains all the necessary mounting accessories for fitting the encoder and is included in delivery of the P96, P115 and P200 series.

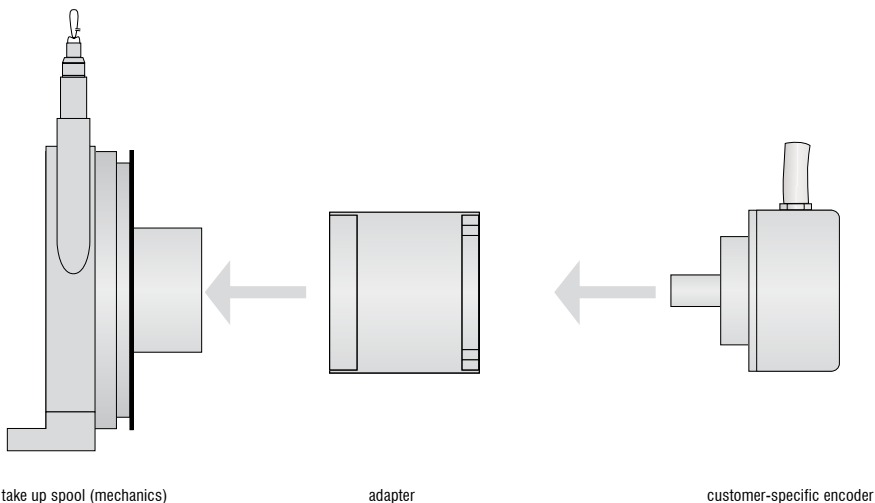

For the customer-specific encoder or potentiometer various draw-wire mechanics are available with measuring ranges up to 50m.

Model	WDS-1500 Z60-M	WDS-3000 P96-M	WDS-5000 P115-M	WDS-7500 P115-M	WDS-10000 P115-M	WDS-15000 P115-M	WDS-30000 P200-M	WDS-40000 P200-M	WDS-50000 P200-M	
Measuring range	1500mm	3000mm	5000mm	7500mm	10000mm	15000mm	30000mm	40000mm	50000mm	
Output	dependent upon encoder									
Linearity	<0.01% FSO	-	-	-	-	<1mm	<1.5mm	<3mm	<4mm	<5mm
	<0.02% FSO	<0.3mm	<0.6mm	<1mm	<1.5mm	-	-	-	-	-
Resolution	dependent upon encoder									
Travel per encoder revolution	150mm	260.09mm	315.07mm				500mm			
Suitable adapter-flange for encoder ø 58mm	clamping flange	WDS-EAC 1	WDS-EAC 96/200	WDS-EAC 115			WDS-EAC 96/200			
	synchro flange	WDS-EAS 1	included in delivery							
Temperature range	operation	-20...+80°C								
	storage	-40...+80°C								
Material	housing	aluminium								
	draw wire	coated polyamid stainless steel								
	ø 0.45mm	ø 0.8mm	ø 1.0mm				ø 0.8mm			
Wire mounting	wire clip	thread M4	eyelet							
Sensor mounting	2 mounting holes	slot nuts								
Wire acceleration	10g	7g	5g	6g	3g	3g				
Wire retraction force (min)	3.5N	5N	4N	8N	8N	8N	12N	11N	11N	
Wire extension force (max)	5.5N	10N	16N	24N	21N	25N	22N	22N	24N	
Protection class	dependent upon encoder									
Vibration	20g, 20Hz...2kHz									
Mechanical shock	50g, 10ms									
Weight	0.3kg	1.1kg	1.4kg	1.9kg	2.8kg	3.2kg	9.5kg	10kg	11kg	

FSO = Full Scale Output

Article description

WDS -	5000 -	P115 -	M -	SO
				Wire brush (only P115/P200)
				Mechanics
				Model Z60/P96/P115/P200
				Measuring range in mm

Model P115

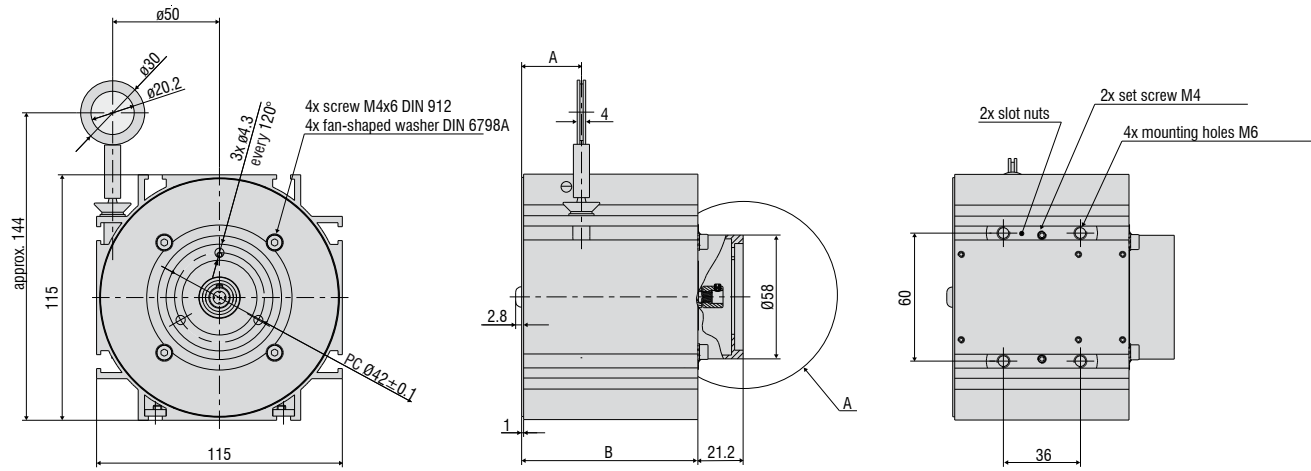

MR (mm)	A (mm)	B (mm)
5000	28	82.5
7500	37	105.5
10000	44.5	148.5
15000	61	180.5

Model P200

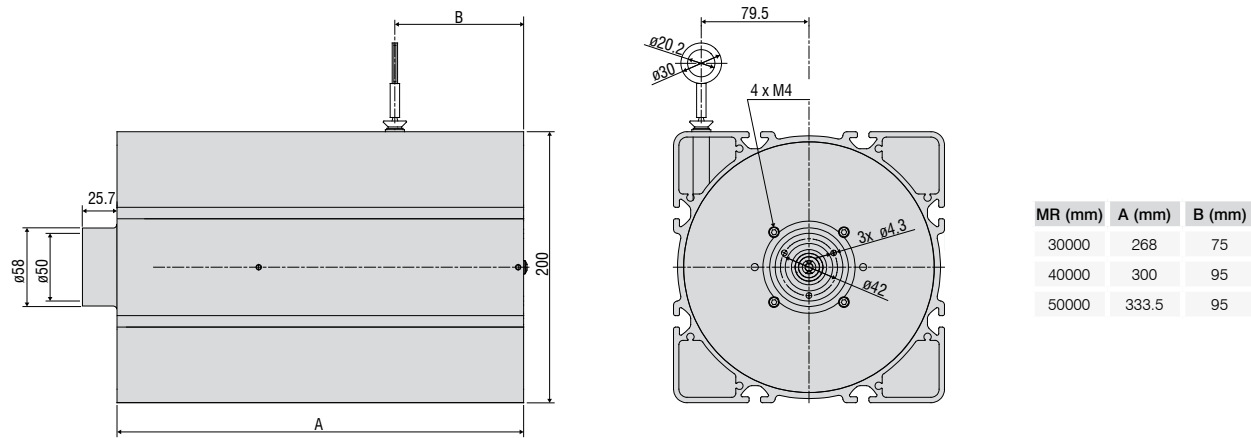

MR (mm)	A (mm)	B (mm)
30000	268	75
40000	300	95
50000	333.5	95



- Use almost any encoder
- Robust plastic housing
- High quality sensor components

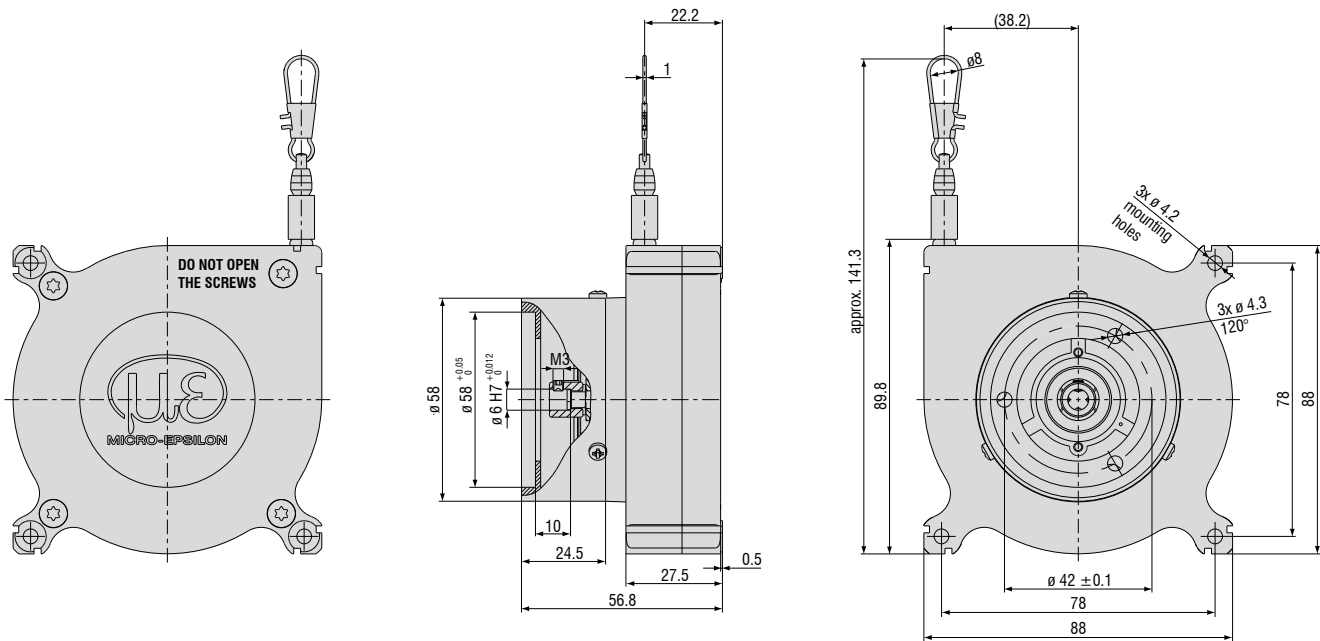

Model	WPS-2300-MK88-M	WPS-5000-MK88-M
Measuring range	2300mm	5000mm
Output	dependent upon encoder	
Linearity	<0.1% FSO ($\pm 2.3\text{mm}$)	<0.4% FSO ($\pm 20\text{mm}$)
Resolution	dependent upon encoder	
Travel per encoder revolution	238.8mm $\pm 0.3\text{mm}$	240.0mm $\pm 1\text{mm}$
Repeatability	$\pm 1\text{mm}$	$\pm 8\text{mm}$
Temperature range	operation	-40...+85°C
	storage	-40...+85°C
Material	housing	PA 6 GF 30
	draw wire	coated polamide stainless steel ($\varnothing 0.45\text{mm}$)
Wire mounting	wire clip	
Sensor mounting	mounting holes	
Wire acceleration (max)	5g	
Wire retraction force (min)	3N	
Wire extension force (max)	9N	
Vibration	20g, 20Hz...2kHz	
Mechanical shock	50g, 10ms	
Suitable encoder	synchro flange $\varnothing 58\text{mm}$; shaft $\varnothing 6\text{mm}$	

FSO = Full Scale Output

Article description

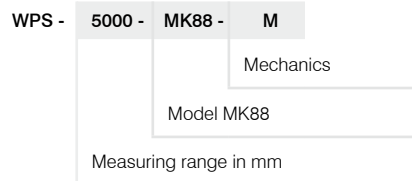

Sensitivity characteristics MK88

The WPS-2300-MK88-M is designed with only one wire layer which is wound onto the drum. This sensor design achieves the highest measurement accuracy.

If a reduced measurement accuracy is sufficient, larger measurement ranges can be achieved with the same sensor dimensions. This can be seen by means of a sensitivity characteristics (see diagram).

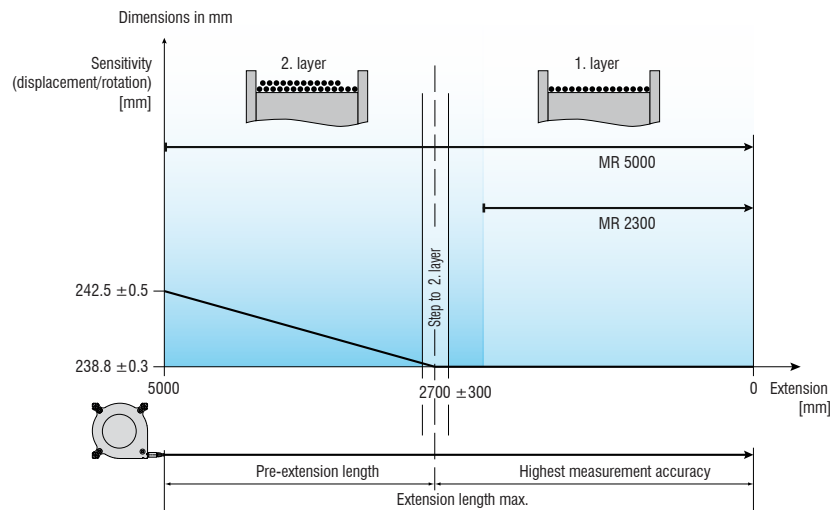

High performance sensors made by Micro-Epsilon



Sensors and systems for displacement and position



Sensors and measurement devices for non-contact temperature measurement



2D/3D profile sensors (laser scanner)



Optical micrometers, fibre optic sensors and fibre optics



Color recognition sensors, LED analyzers and color inline spectrometer



Measurement and inspection systems